

More Open Ceiling.

The open ceiling ratio
is $\frac{3}{4}$ in the new
generation SKYFREE.

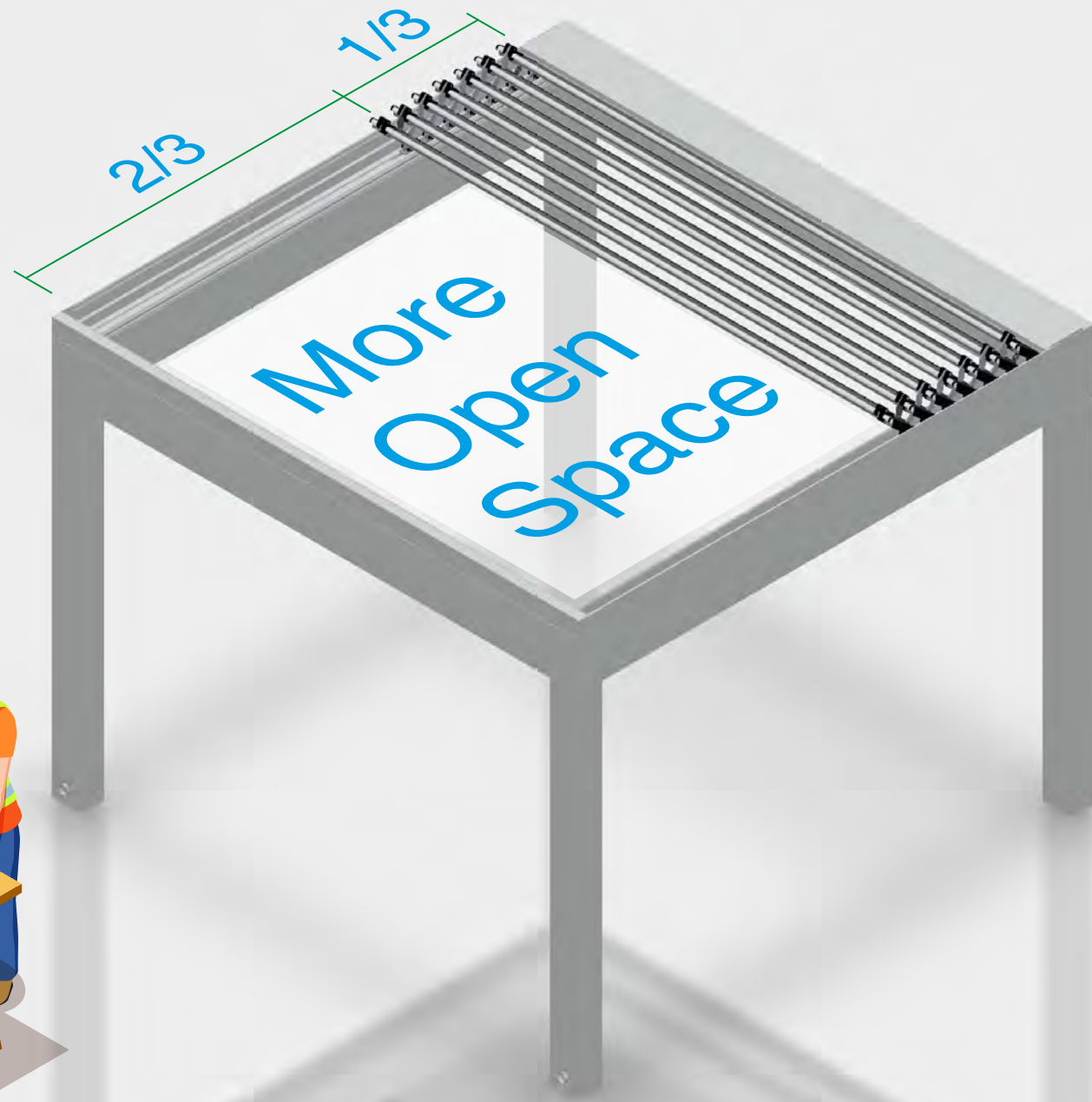

Powerful System

With only a 4-legged system, you can increase your living space by **24.5 m²**



**Umbrella
under the
SkyFree?**

**Of course
funny...**

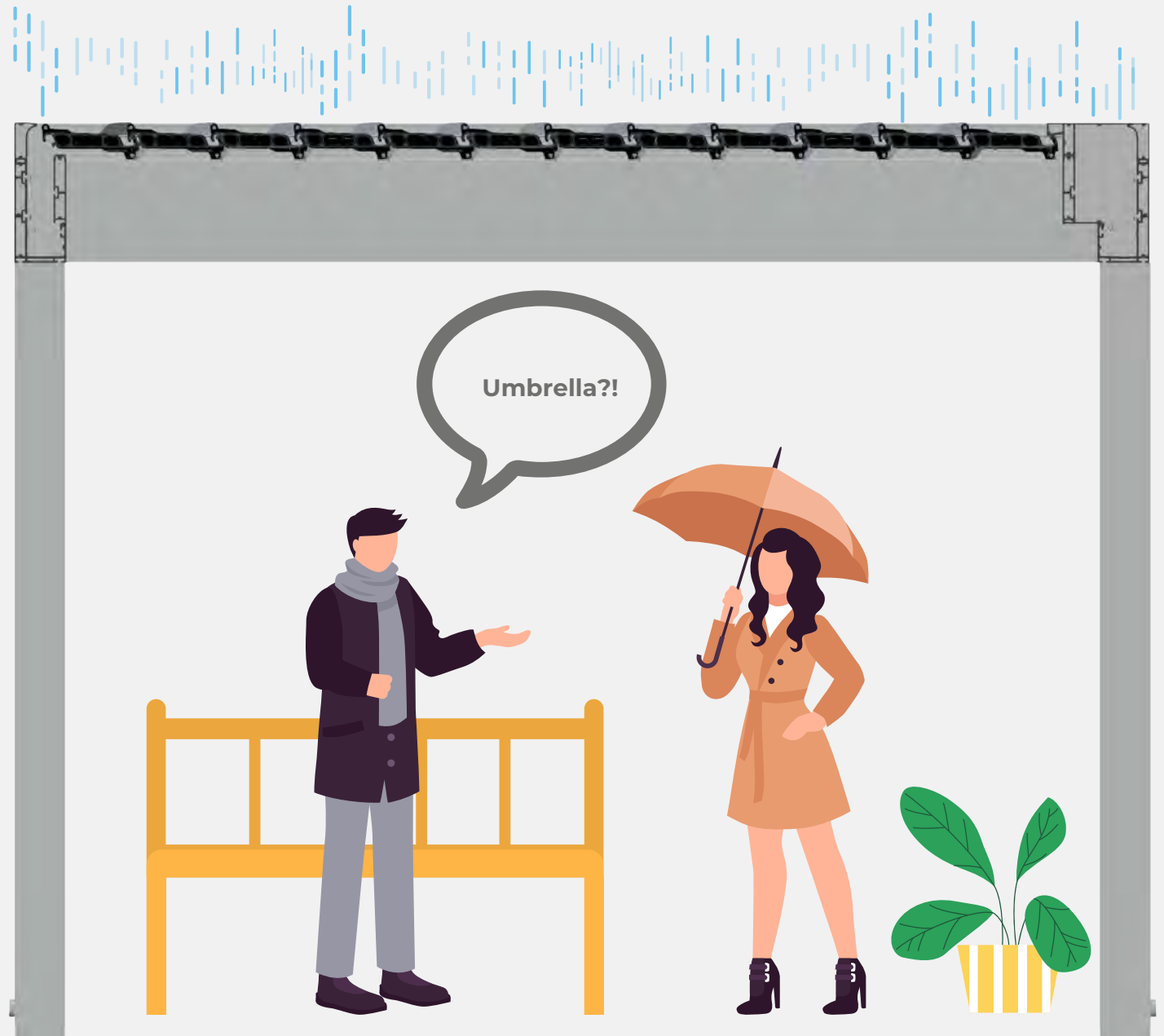

SKYFREE drainage solutions

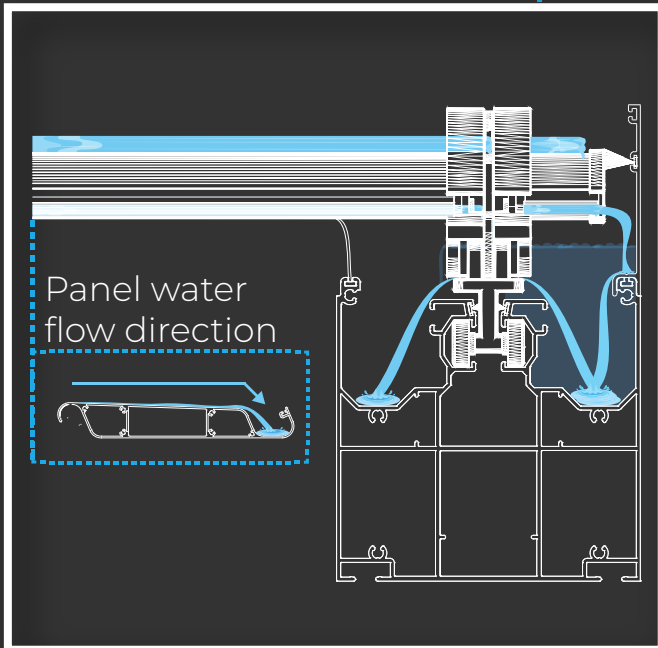
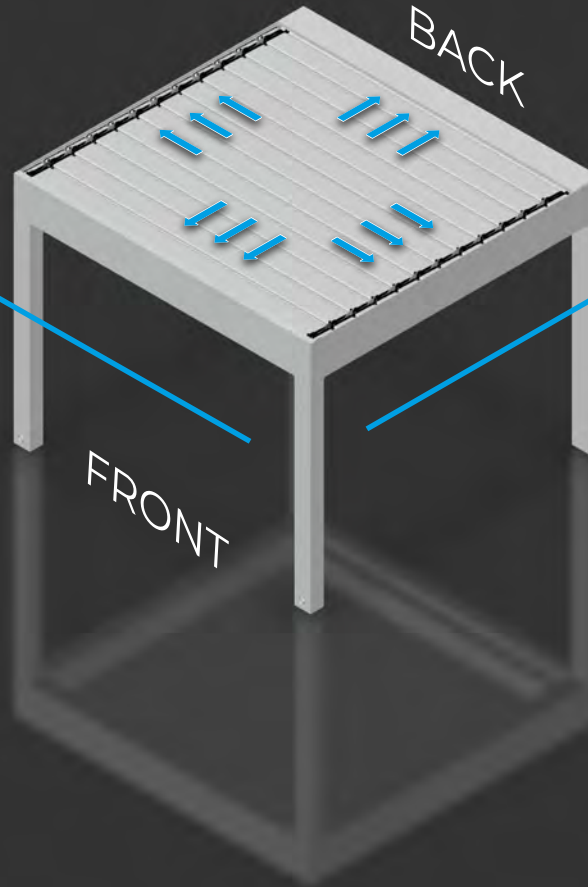
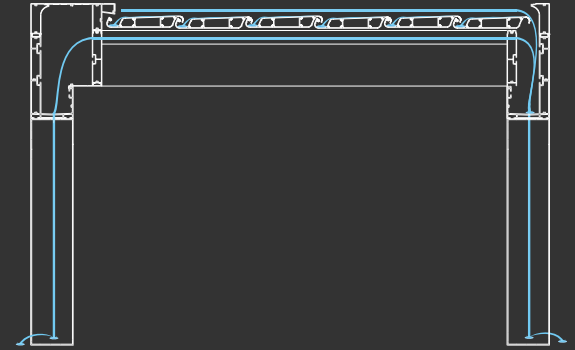
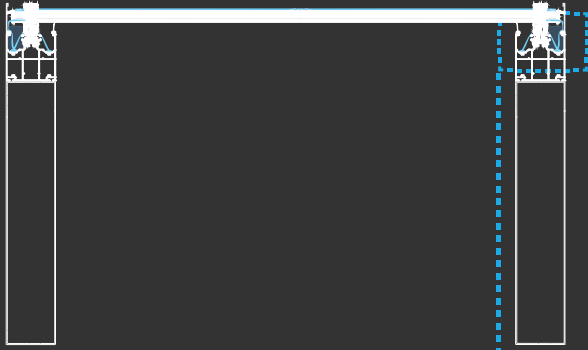

In our new generation SKYFREE models, we made special additions to the water drainage solutions in the rail-panel junction points and side cover designs. The water, which is directed sideways from the panel-rail junction point over the panel, is transferred to the double grooves in the rail for water discharge. If under heavy rain conditions, excessive water puddle occurs and the water overflows to the sides, it cuts the water on the side covers and directs it to the gutters.

WATER

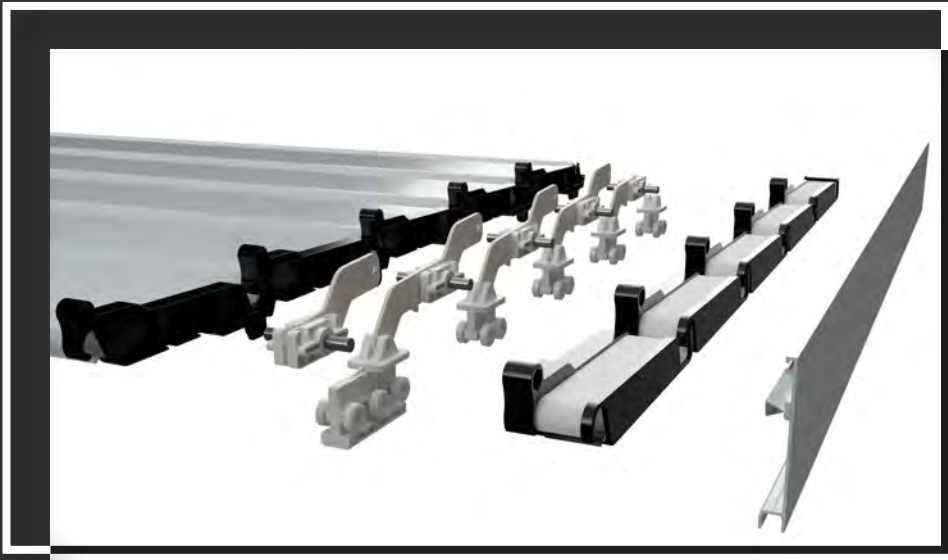

In our **SKYFREE** models, each panel is designed inclined towards the back, and they collect the water accumulated on it in the small groove formed by the folds on the back and the water movement starts to the sides.

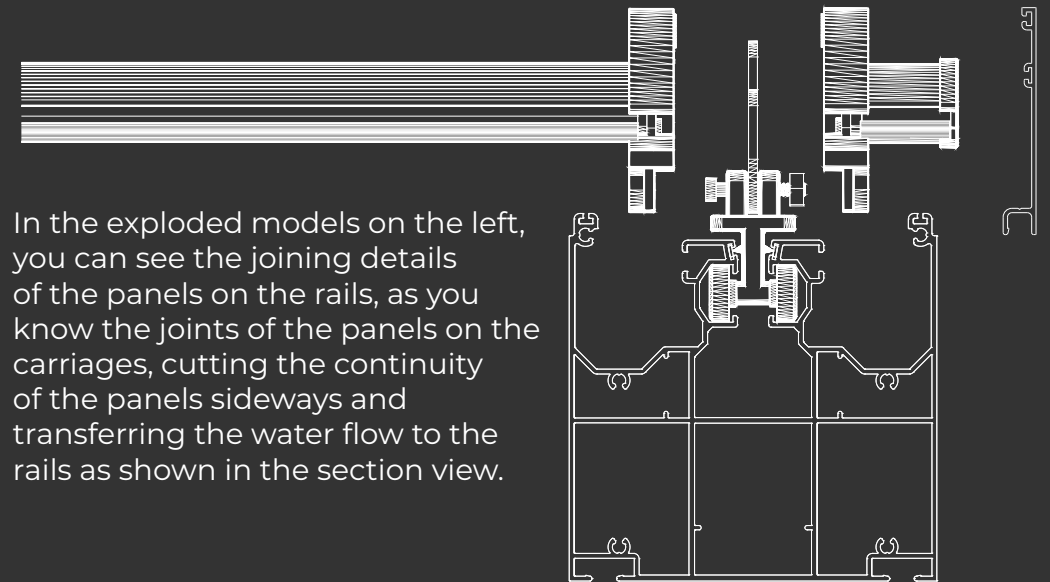

In the exploded models on the left, you can see the joining details of the panels on the rails, as you know the joints of the panels on the carriages, cutting the continuity of the panels sideways and transferring the water flow to the rails as shown in the section view.

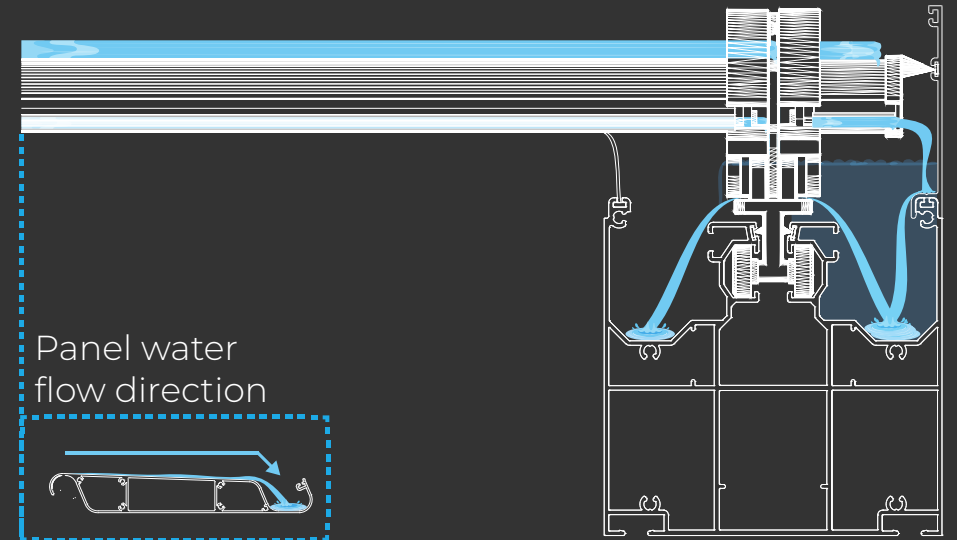

Panel water flow direction



DUST

In our new generation SKYFREE models, we designed two-sided slots that move through the rails, in order to keep the movement of the cars perfectly always, to add weather strip to the rails. With these slots, dust and small particles are prevented from entering the car path. The movement of the panel continues with the quality of the first day.

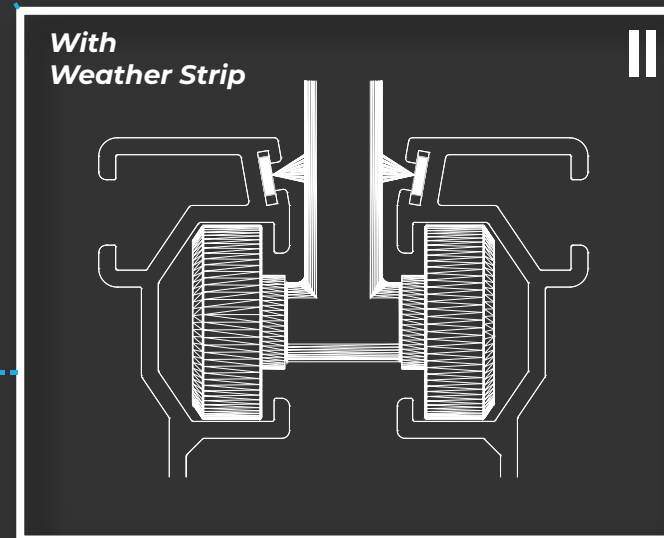
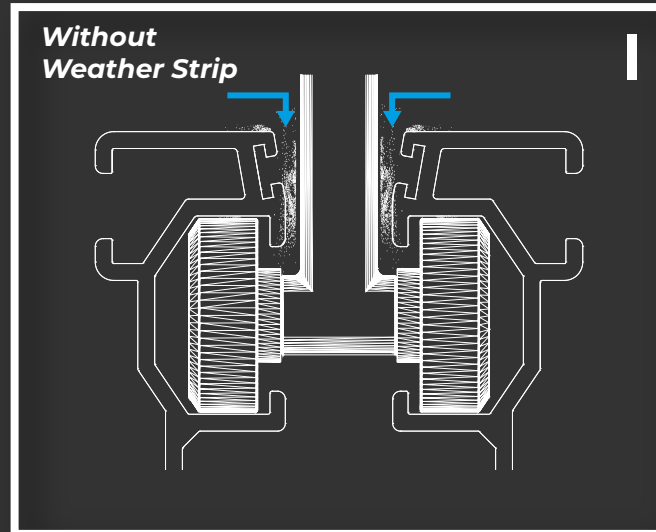
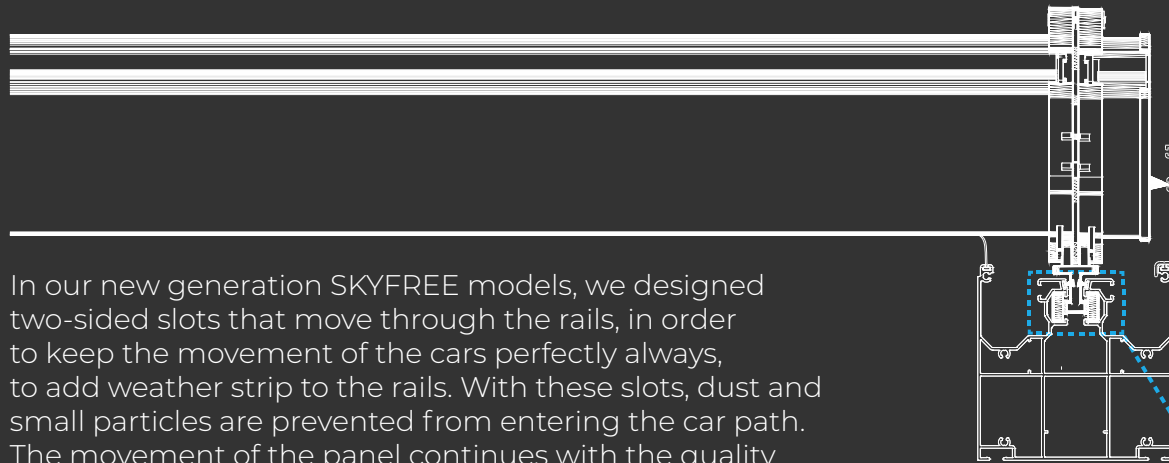
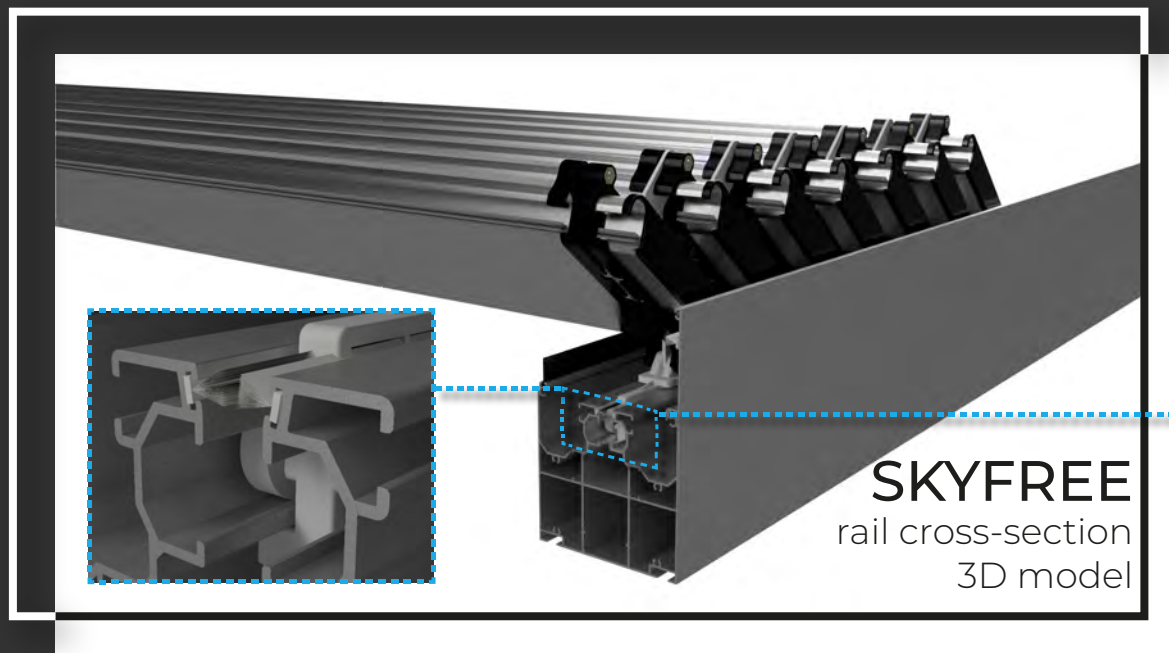

DUST

The new **SKYFREE** rail side covers are specially designed both aesthetically and technically. Cover profiles have been added to cover the detailed system view from the sides. Weather strips added to the inside of these profiles prevent dust and small particles from entering the system.

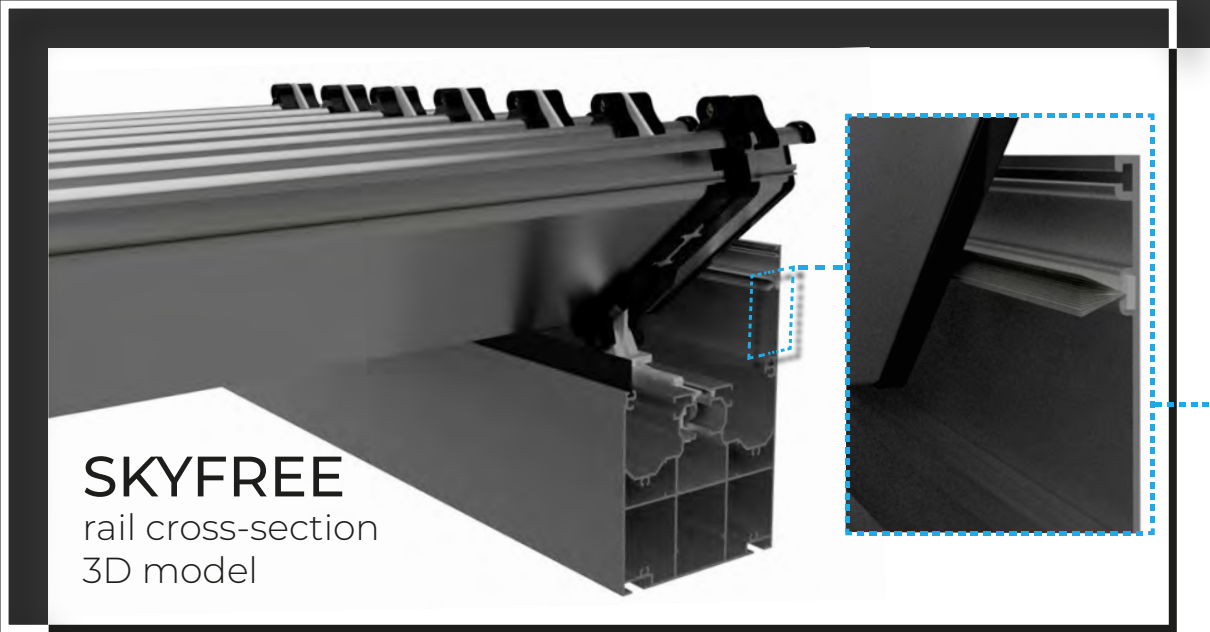
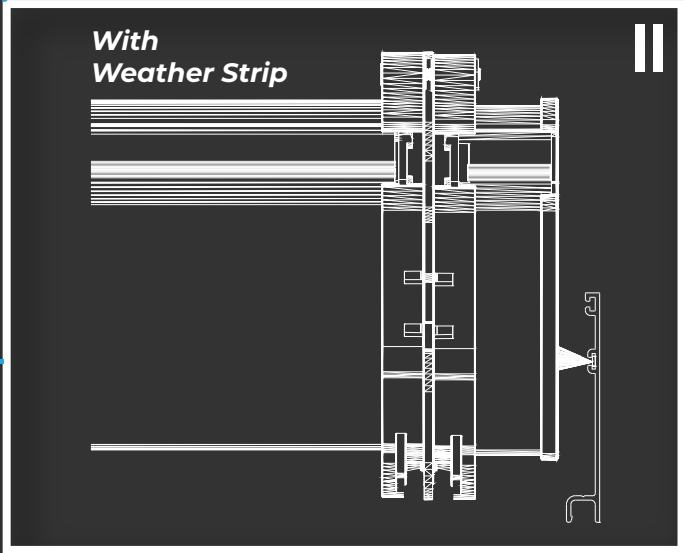
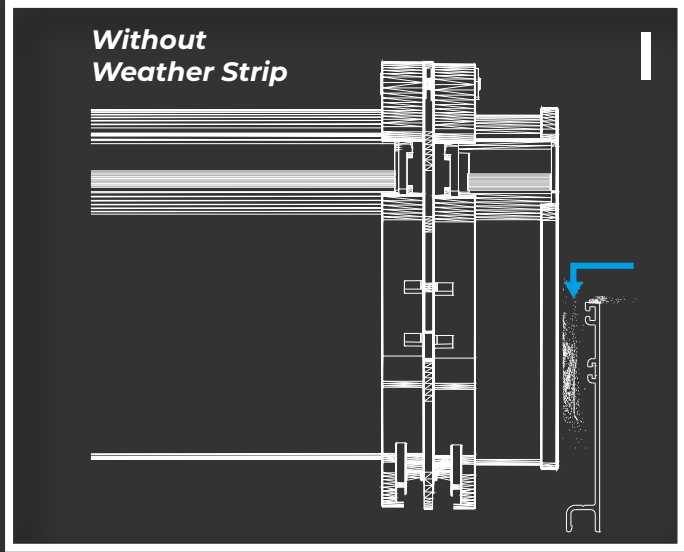
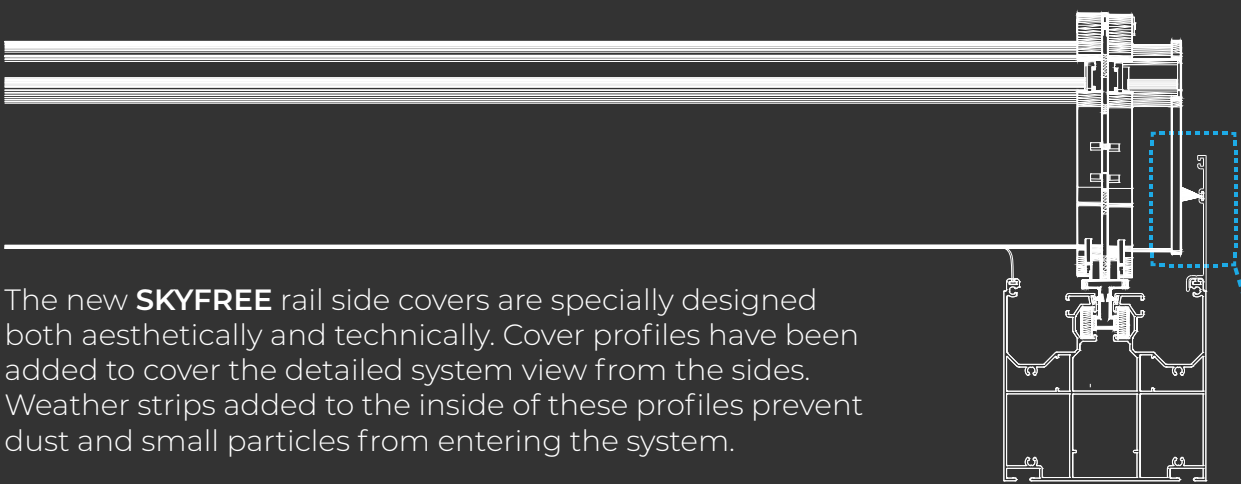

SKYFREE
rail cross-section
3D model

High Quality Material



WEATHER STRIP - We added gaskets, and weather strips in every connection and docking points, for closing small spaces for preserving materials.

STEEL - Skyfree system includes high steel connector with gold and silver covered.

ALUMINUM - Ever panel and panel side parts designed from aluminum.

PLASTIC - Panels side caps, moving cars, made from strong plastic materials against hard weather conditions and impact.

**Perfect
Lighting...**

**But
If there any
problem**

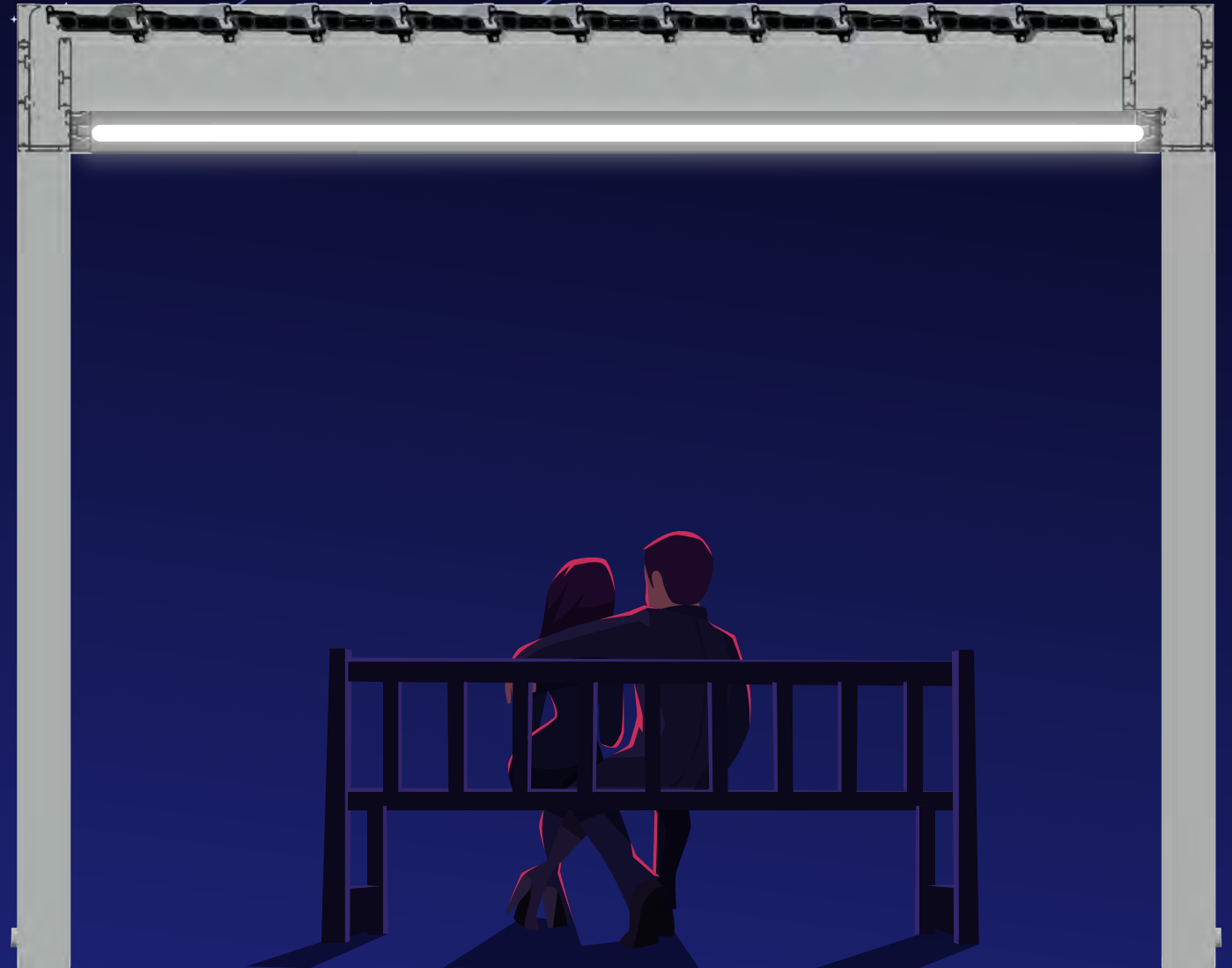

Easiest problem solving

Easy repair card-lighting systems.
If any lamp fails, it is possible to quickly replace a single board. And we are present to our customers with different color options.

